

5, rue de la Verrerie
38120 Le Fontanil (France)

Tel : + 33 476 26 1976 - Fax : + 33 476 26 2593

www.tcube.tv

Solutions for Teletext services and Subtitling in HD and SD

By Jean Luc Grimaldi, Tcube Marketing Director

Updated on June 29th 2010

Introduction

Recent European regulations concerning the mandatory subtitling for hearing impaired people of broadcasts require products for data insertion into HD feeds. More generally, requirement for ordinary subtitles and teletext services embedded with HD signals create new opportunities and challenges.

Identification of key issues and bottlenecks

Teletext services are currently in wide use for analogue composite transmission. During DTV transition, these services have been and are still widely ignored. **EU requirement** for providing subtitling data service for hearing impaired people has now changed the deal, especially because the requirement applies indifferently to SD and HD DTV signals, whatever mode of distribution (conventional broadcast - either terrestrial or satellite - and Telco ADSL or cable).

In this period of low water, **protecting past investment** has become a critical issue and any solution that uses already in use services like SD teletext is highly appreciated.

Capacity of **monitoring inserted data** before DTV encoding and transmission is perceived as a very significant decision factor. In environments where coded data go through very complex architecture (like encoding, encrypting and transmission facilities), monitoring signal content at the input in a visual way (like burn in subtitle) is a very good discriminator in terms of **service quality**, especially when such services are not permanent.

In SD, **Teletext** has been in use since the early 80s. Complete service devices exist for generating and formatting pages and live video insertion.

While analogue waveform decoding of SD Teletext lines are a trivial practice for acquiring Teletext data, Teletext data can also be generated from a TCP-IP raw data line under the Newfor protocol and Subtitle files are also commonly generated as STL files (EBU3264).

Existing Protocols for data insertion

In HD native, **OP47** has filled the gap by proposing a practical solution for insertion of Teletext data as an ancillary data channel in HD. Originally OP47 was developed by Australian broadcasters for internal use –OP47 is the acronym for Operational Practice number 47 under Australian labelling-. It has been widely accepted and used in the international community.

A data format, that can be used either for HD native or ASI formats, has been formalized by SMPTE under reference **S2031M**.

S2031M is globally identical to OP47 though using a different encapsulation protocol.

In fact, OP47 or S2031 are pragmatic solutions having all qualities required for providing a Teletext service in HD channels at very low cost. They use existing Teletext infrastructures, are easy to implement and easy to monitor. MPEG encoders support one of these (either OP47 or

S2031). Data transported using on of the protocols are encoded as DVB service for terrestrial, satellite or ADSL transmission.

Tcube approach

After a market survey with European broadcasters, three operational architectures were identified.

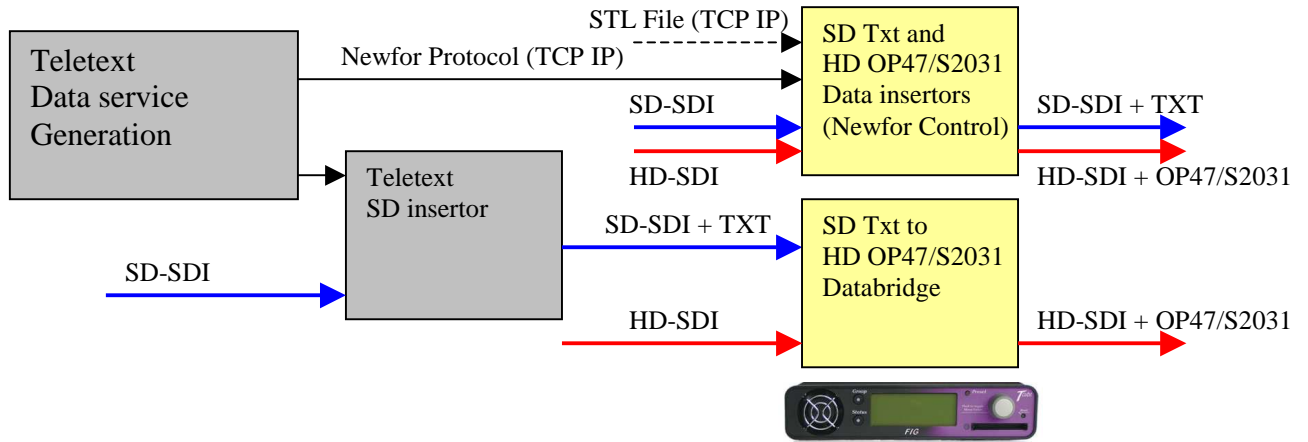

A1: TXT and OP47/S2031 Data insertion in live SD and HD streams

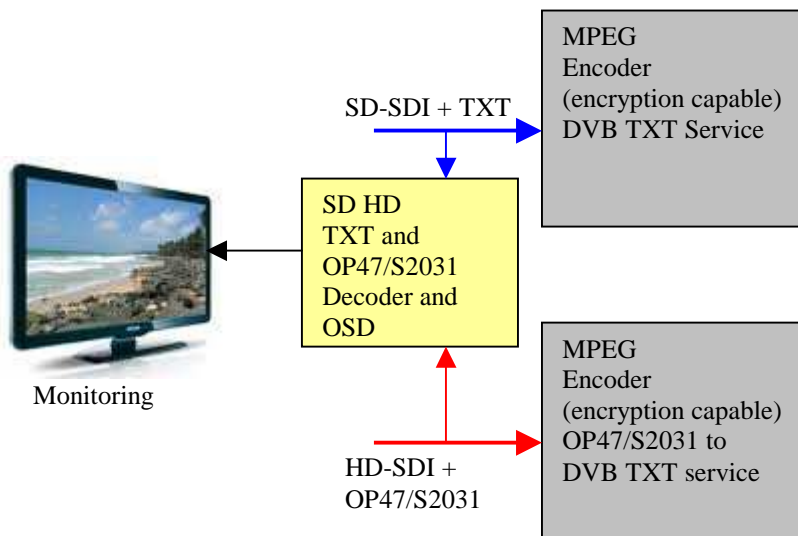

A2: Service verification: TXT and OP47/S2031 Monitoring before MPEG encoding

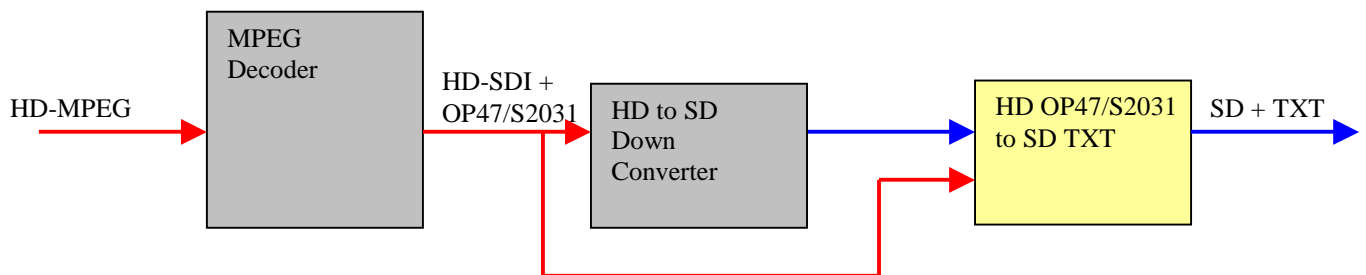

A3: SD TXT regeneration after HD to SD Down Conversion

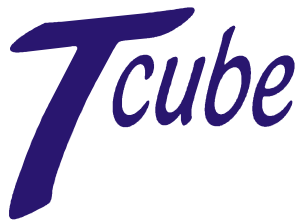

5, rue de la Verrerie
38120 Le Fontanil (France)

Tel : + 33 476 26 1976 - Fax : + 33 476 26 2593

www.tcube.tv

A1 describes the organisation for inserting TXT into SD or HD either directly from a TXT data generator using Newfor protocol or by databridging SD-TXT onto HD-OP47/S2031.

Tcube application for Databridging SD onto HD is **VB509**

Tcube application for Newfor TXT generation (SD and HD simultaneously) is **VB609**

VB609 is also capable of inserting TXT data (SD or HD) from a STL file. STL files are devoted to subtitling coming TC information and TXT content.

Both application run on a Tcube FIG Hardware.

A2 is a monitoring application used to check TXT content either on SD or HD feeds on a video monitor (TXT burned in), making sure that TXT service is present and adequate.

Tcube application for TXT monitoring (SD and HD simultaneously) is **VW609**

The application runs on a Tcube FIG Hardware.

A3 is a 'special' reception implementation designed to save transmission costs when having to broadcast SD and HD simultaneously regionally. Imagine overseas transmission to islands or territories.

Tcube application for Databridging HD onto SD is **VB519**

The application runs on a Tcube FIG Hardware.

Conclusions

The Tcube offer for Teletext insertion and decoding addresses different market segments. It provides solutions allowing use of past investment (teletext page generators e.g.) while providing monitoring capabilities, and ensuring high quality level.

Besides SD to HD databridges, Tcube also addresses SD only segments (like Teletext Filtering for bit rate limitation) and HD only segment like OP47-S2031 protocol transcoders.

By providing off the shelf applications and a quick-response customisation facility, Tcube intends to continue fulfilling customers' needs in a very tight manner.

About Tcube

Tcube is a manufacturer of video products established since 2002 in the French Alps. Tcube has different ranges of product lines like VBI management, color correction and legalization, logo inserters ...