

INS/OUTS

2 HD/SD SDI Ins (1080i,720p,525,625 auto sense)
 Inputs have Bypass Relay
 6 HD/SD SDI Outs
 4 GPI In and 2 GPI Outs
 1 RJ45 100base_T Ethernet

GPI

Complete configurations can be recalled from GPI

Signal processing

Except for BI549 and BI559, signal processing is entirely done in YUV (4:2:2) to preserve background picture quality
 Full RGB signal processing in version BI549 and BI559
 Multi-layer capabilities: A maximum of 4 layers, one per Bug
 Supports bug transparency
 Totally independant processing of each output
 Preserves embedded audio and VBI content

BUG/LOGO Management

All controls possible by using **DAZIBAO**, software under WinXP:
 - Bug/logo selection,
 - Picture Positioning,
 - Layer selection,
 - Bug transfer from PC and storage inside FIG

BUG/LOGO Characteristics

- R, G, B, Alpha TGA or BMP mode
 - Local storage on internal Flash (max 2MB)
 - 1:1 resolution (1 pixel of Logo is displayed as 1 pixel on Output)
 - Supports animated logos (succession of TGA or BMP or pictures or uncompressed AVI)

DIMENSIONS (FIG)

44mm (H) x 205mm (W) x 325mm (L)
 Rack mounting with **RM1** option (2 units in 1RU)

WEIGHT

2.5kg (without power supply)

POWER

FIG comes with an external 100-240V power supply
 Optional redundant power supply (RPSU)
 Power consumption: less than 20W

All specifications of this brochure are subject to change without notice. They are given for information only

ORDERING INFORMATION

FIG	Universal HD-SD SDI to HD-SD SDI OS free computer External 12V Power Supply
BI500/509 BI520/529	Single Input, Dual Outputs Bug Inserter (1 Bug, 1 Layer per output) Single Input, Dual Outputs Bug Inserter (4 Bugs, 4 Layers per output)
BI510/519 BI530/539	Dual Channels Bug Inserter (1 Bug, 1 Layer per channel) Dual Channels Bug Inserter (4 Bugs, 4 Layers per channel)
BI559	4x4 (RGBK/YUVK) Bug Inserter (4 Bugs, 4 Layers)
RM1	Rack mounting mechanics for 1 or 2 FIG modules
RPSU	Redundant & Hot Swap external Power 12V Supply

Doc 2008-0--BI-V1.10

BUG INSERTER

Software solutions developed on FIG hardware platform

Single Input Dual Outputs Bug Inserter
 (1 Bug - 1 Layer or 4 Bugs - 4 Layers per output)
 BI500 (SD) BI509 (HD/SD) on FIG
 BI520 (SD) BI529 (HD/SD) on FIG

Dual Channels Bug Inserter
 (1 Bug - 1 Layer or 4 Bugs - 4 Layers per output)
 BI510 (SD) BI519 (HD/SD) on FIG
 BI530 (SD) BI539 (HD/SD) on FIG

4x4 (upgrade) Bug Inserter (4 Bugs - 4 Layers)
 BI559 (HD/SD) on FIG



Tcube

FIG

OS-free 'computer' designed for dual link HD, HD, SDI
 Second to none

FIG has everything to suit your needs
 Dual HD or SDI Inputs with Bypass relay
 HD or SDI Outputs
 Redundant Power Supply
 Ethernet connection
 GPI I/O
 Field upgradable firmware from Compact Flash



5 RUE DE LA VERRERIE 38120 LE FONTANIL (FRANCE)
 TEL: +33 476 26 1976 FAX +33 476 26 2593
 SALES@TCUBE.TV

WWW.TCUBE.TV

Tcube, 5 rue de la verrerie 38120 Le Fontanil (F)
 Tel: +33 476 26 1976 Fax +33 476 26 2593 e-mail sales@tcube.tv

BUG INSERTER

General functionalities

Serial SD/HD-SDI Inputs
 Serial SD/HD-SDI Outputs
 2 GPI Out, 4 GPI In all potential free
 User selectable GPI controls
 100baseT Ethernet network connector
 1RU height, half 19" width (2 units in 1RU)

Upto 4 layers Bug/logo Inserter
 Dual outputs or Preview/Program mode
 Full transparency of embedded audio data and VBI content
 Automatic detection of Input format standard (HD, SD, Progressive, Interlaced)

All popular bug graphics formats supported: TGA, BMP, AVI
 Transparent Aspect Ratio (1 pixel in file is displayed as 1 pixel on Video)
 Animated logos

DAZIBAO functionalities for BI family

GUI running under Windows/XP (free of charge)
 100 baseT Ethernet communication
 Direct access to all functions of BUG/Logo Inserters
 Upload of bugs into FIG Hardware
 Preview of Bug Contents
 Page composition

FIG

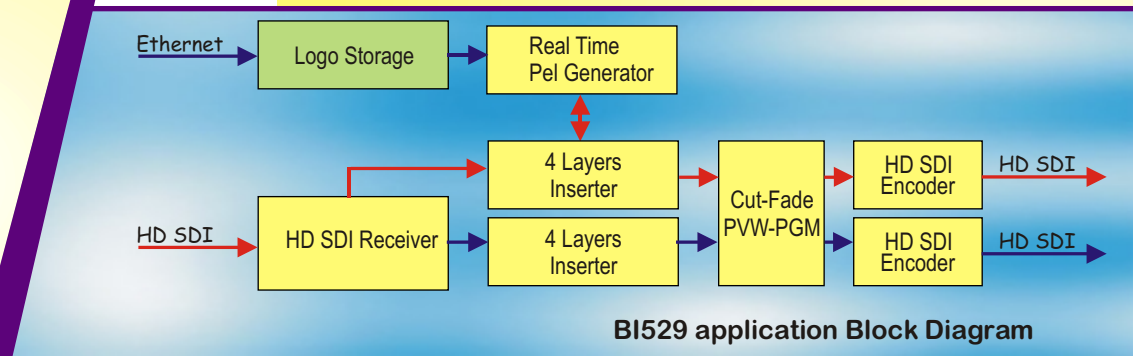
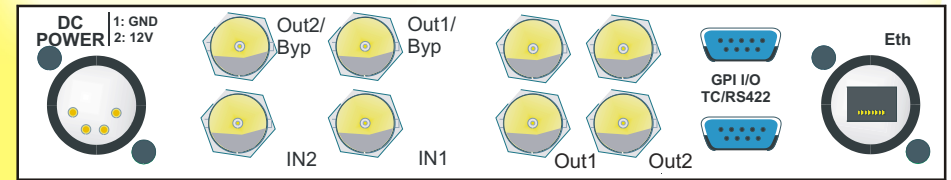

Tcube